

**Aufständerungssystem 35°
 Set 4 Module - Hochkant**

Warnung !

Die Aluprofile sind scharfkantig,
 bitte arbeiten Sie mit Handschuhen.

Die Aufständerungsdreiecke
 werden nur einseitig verschraubt.

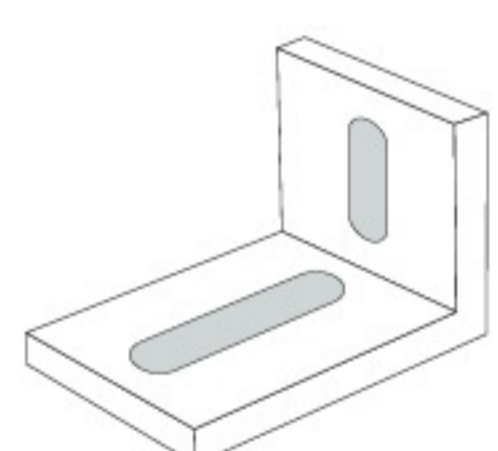
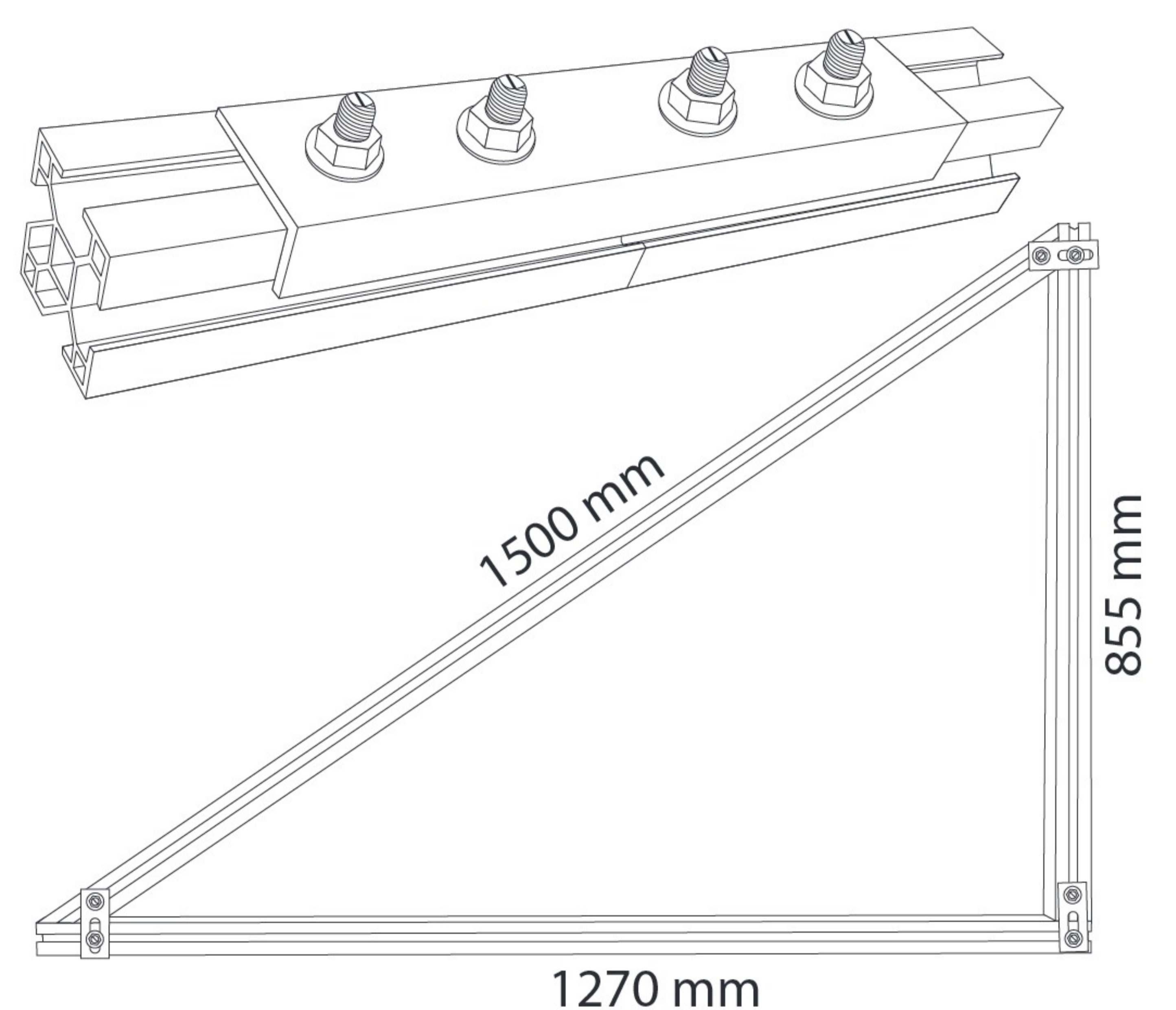
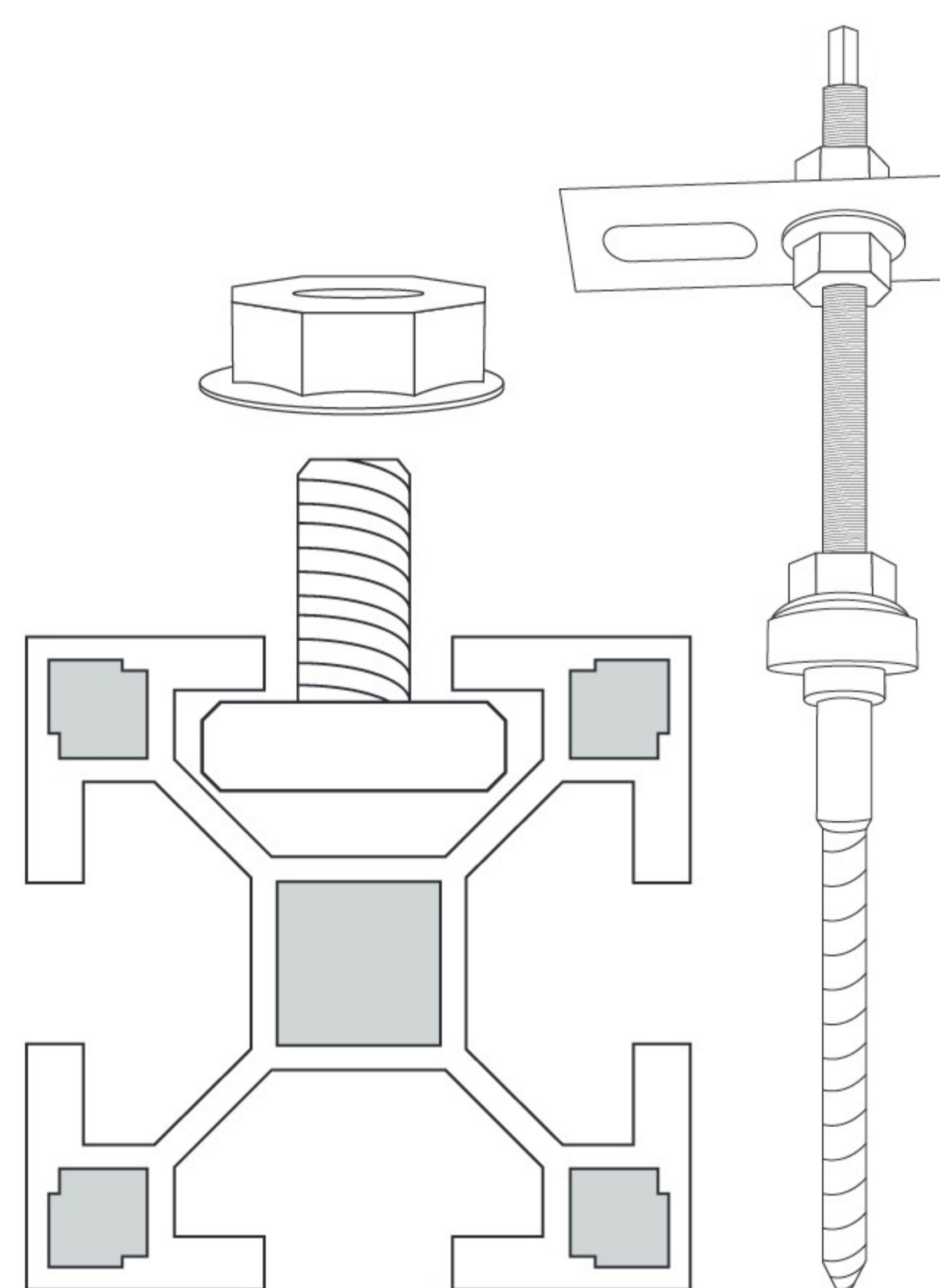
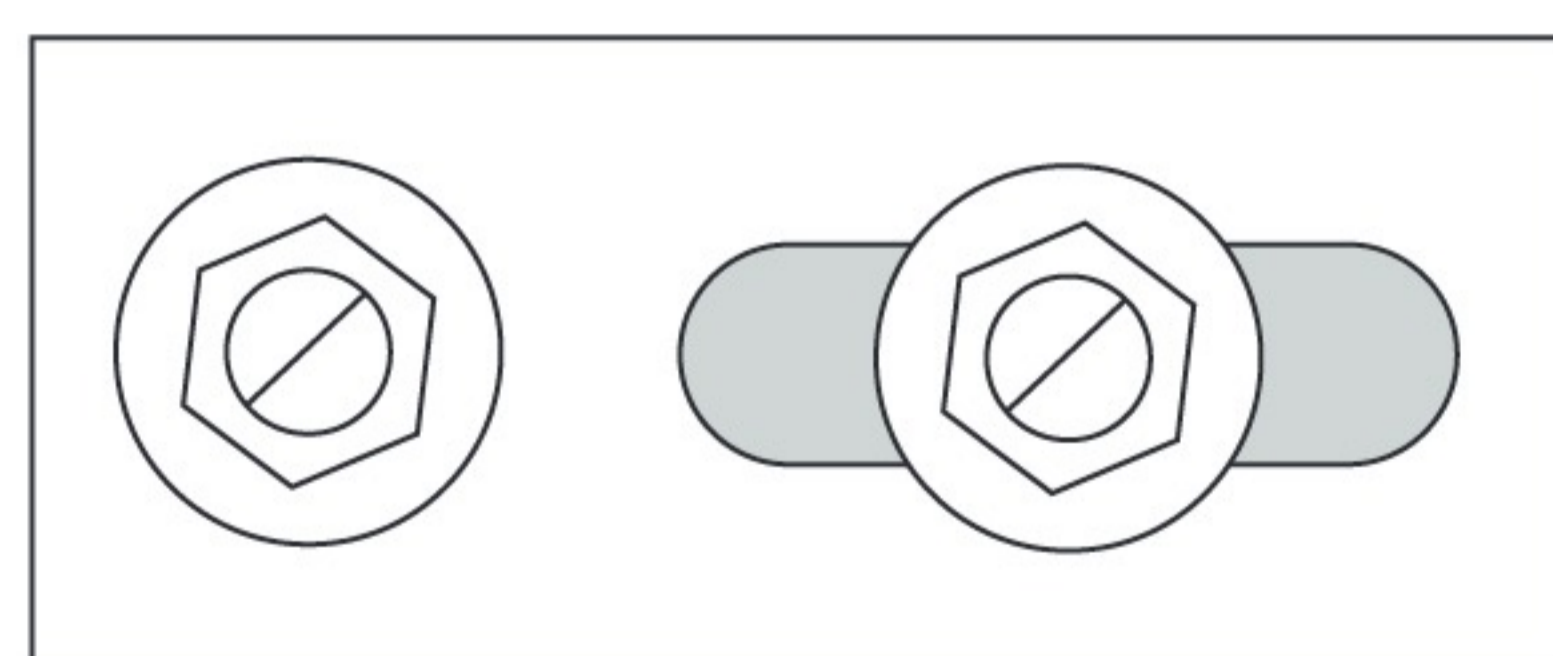
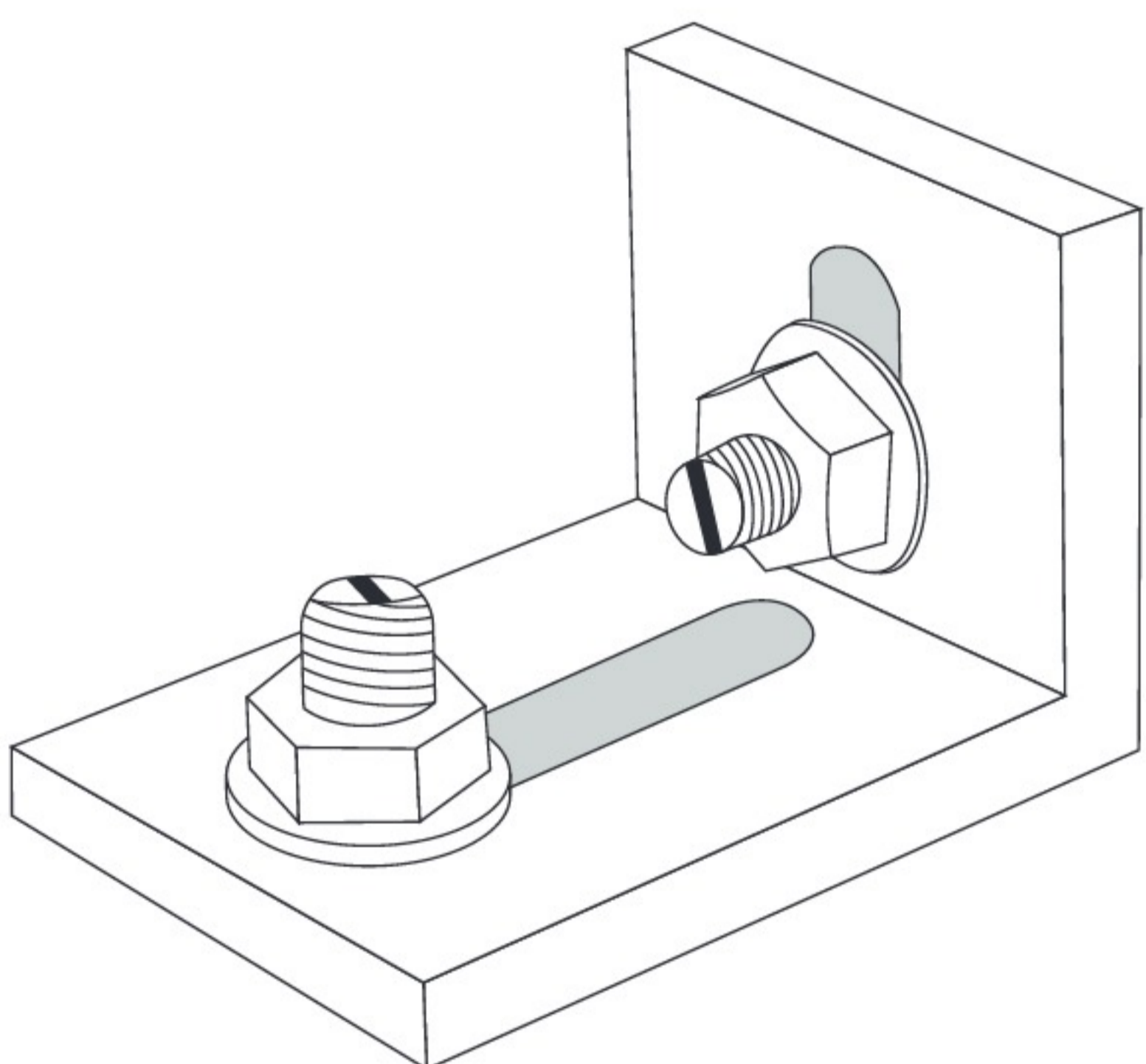
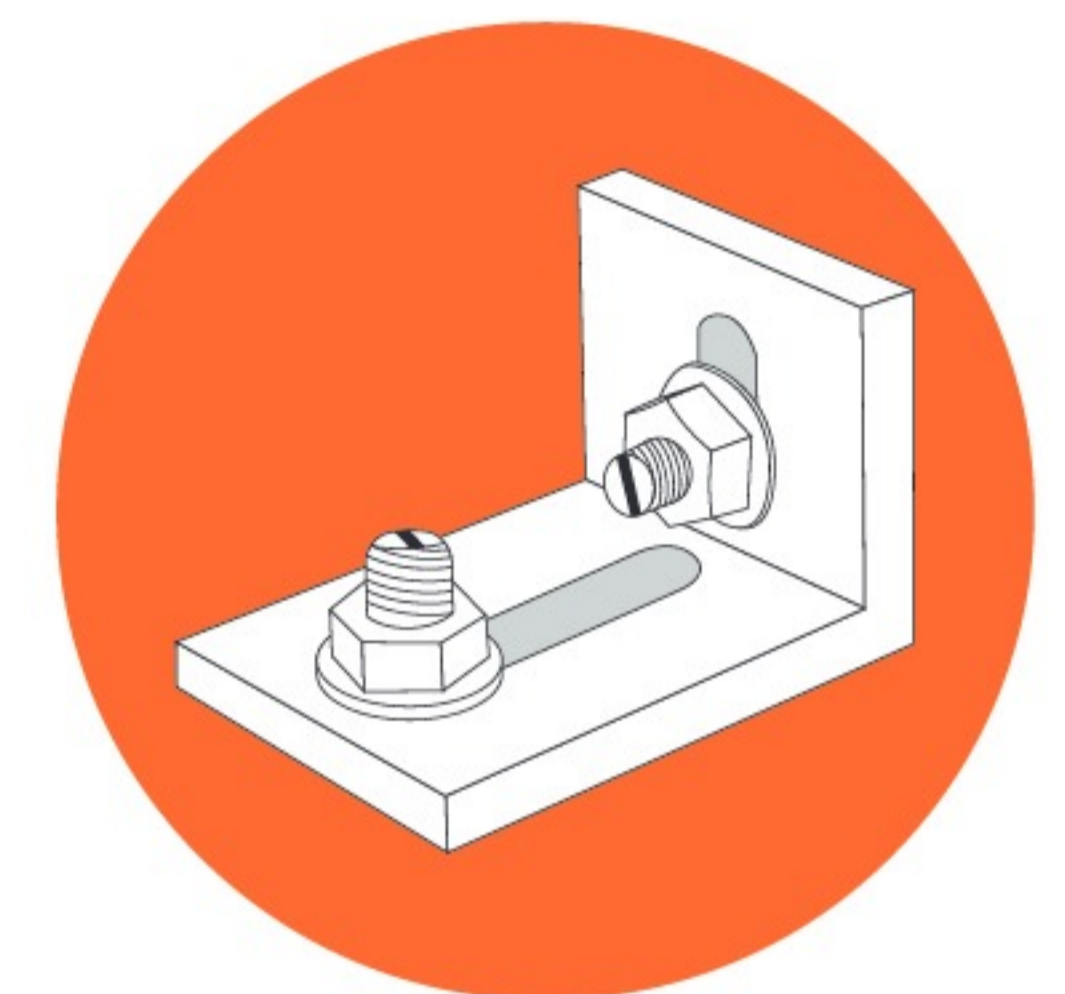
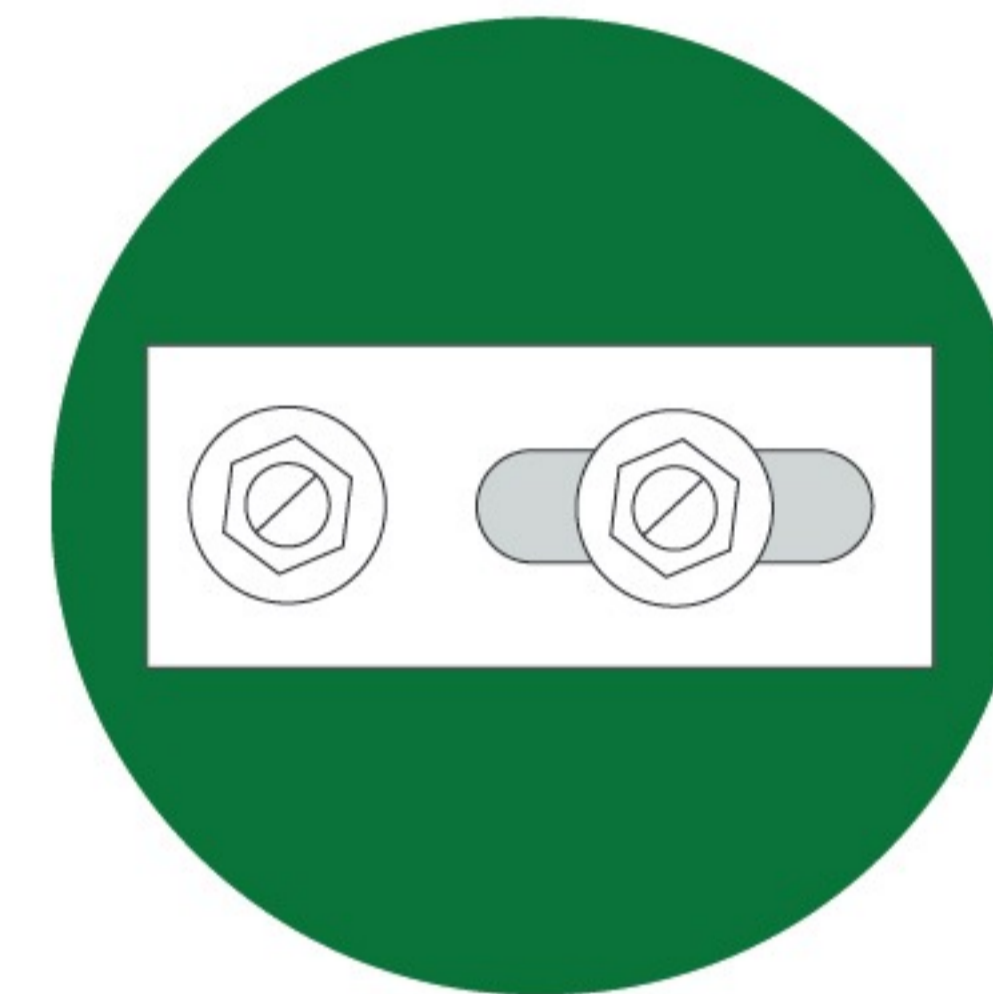
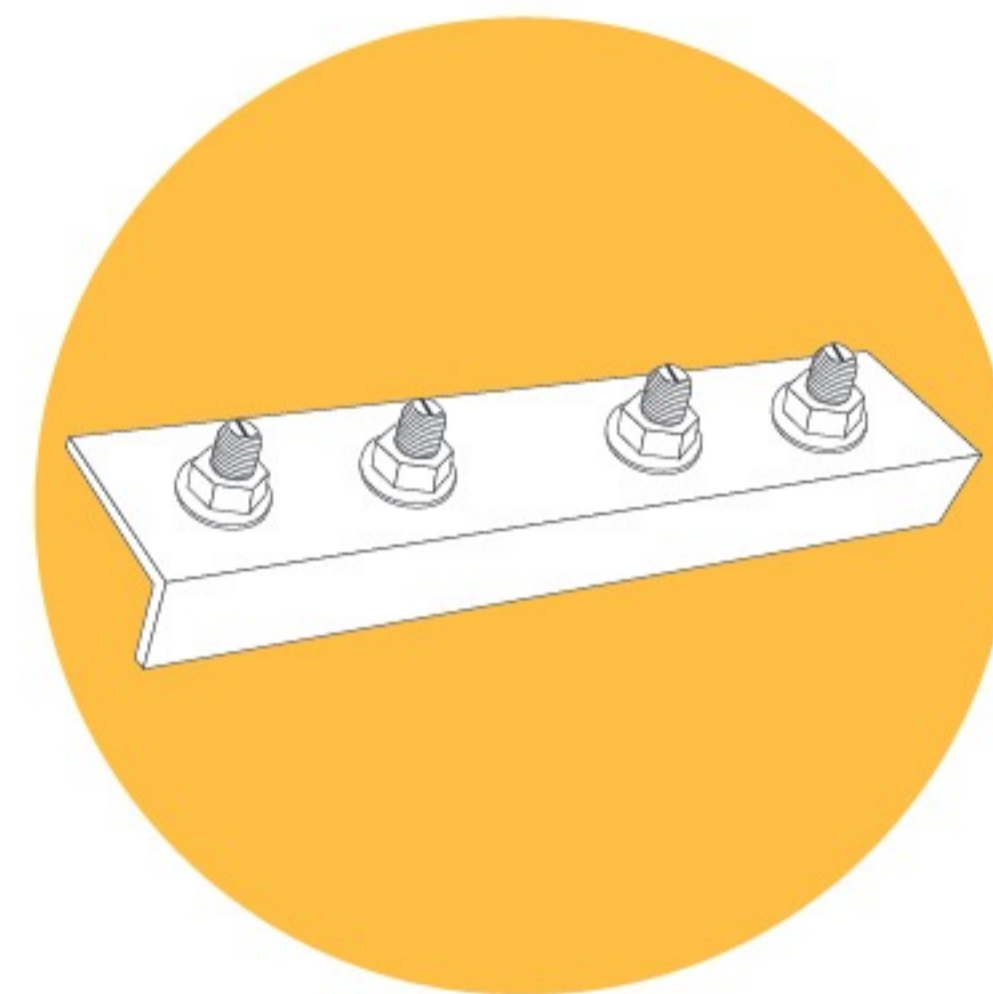
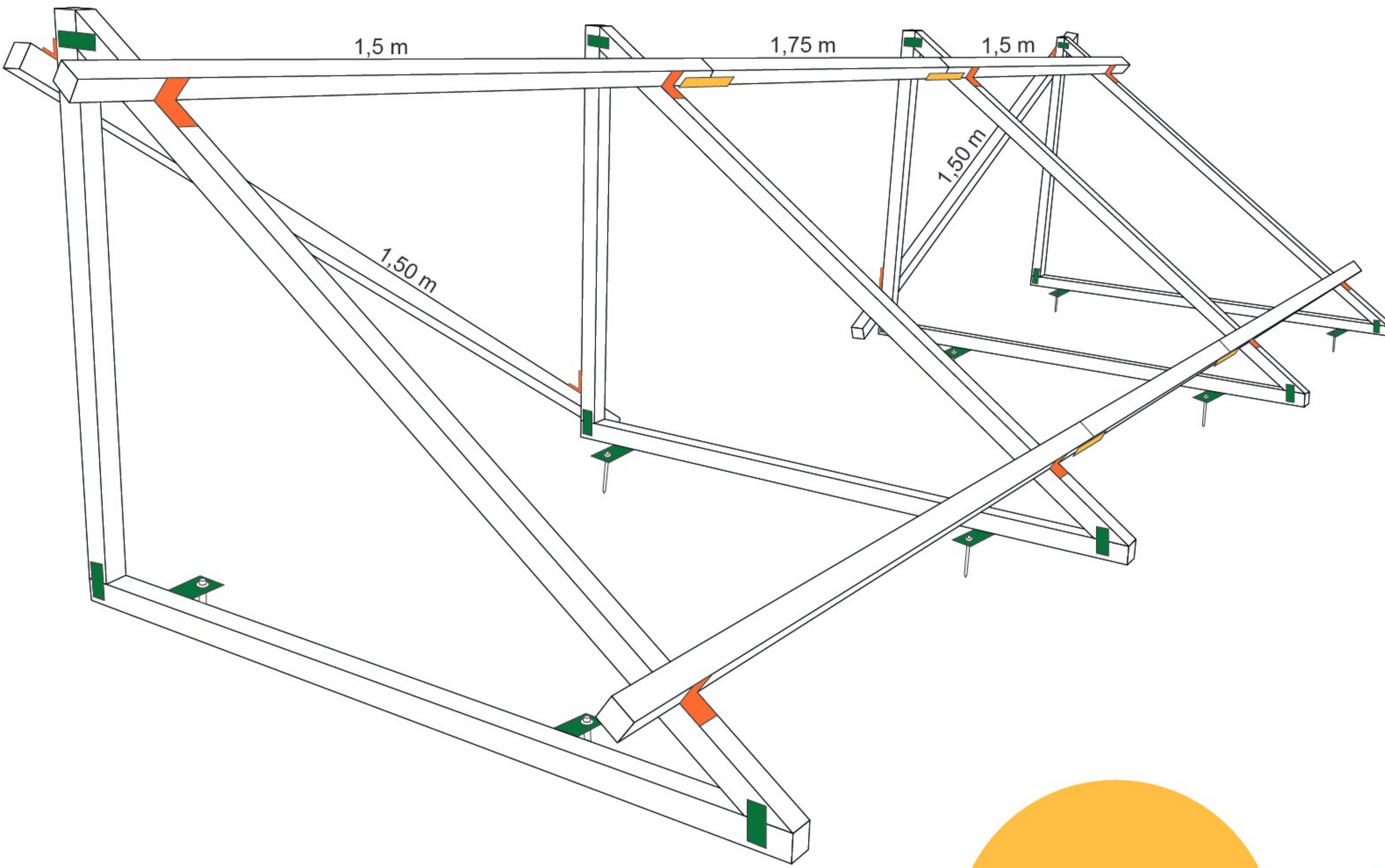

12x

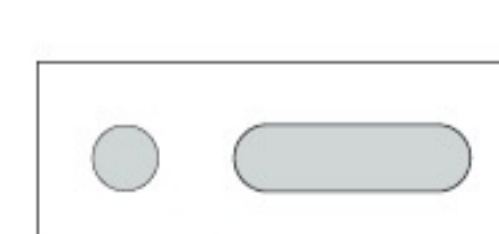

20x

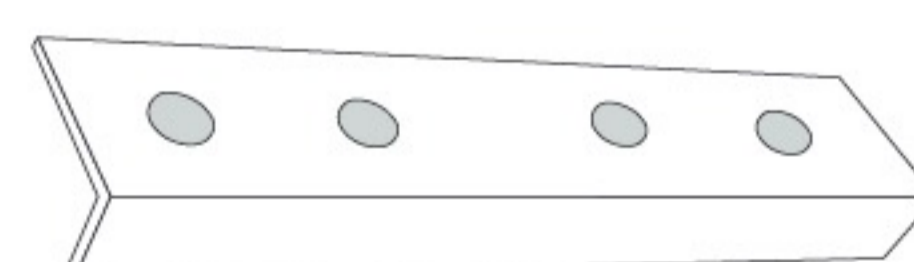

4x

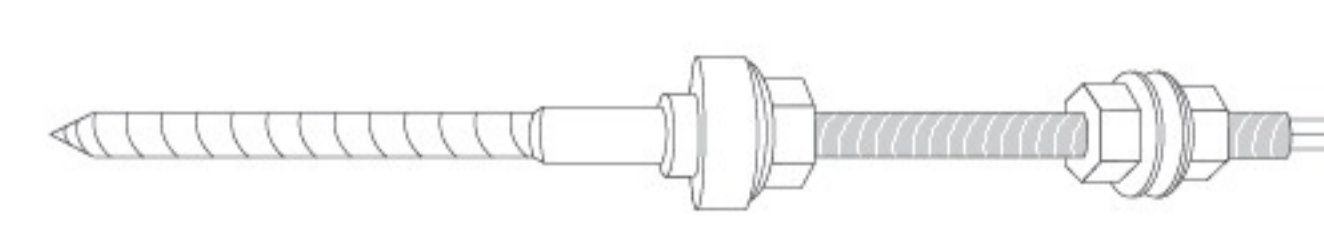

8x

 4 x 1500 mm

 4 x 855 mm

 4 x 1270 mm

 6 x 1500 mm

 2 x 1750 mm